

## Design and Impletation of Tube Heat Exchanger with Discontinuous Twisting Baffles With Computational Fluid Dynamics Analysis: A Review

Ashutosh  
M.Tech Schollar  
ashusharma1573@gmail.com  
Mittal Institute of Technology, Bhopal

Dr Kirti Chawara  
Assistant Professor  
kirtiuechaware@gmail.com  
Mittal Institute of Technology, Bhopal

**ABSTRACT :-** Heat exchanger is an apparatus to carry heat from one channel to another. Due to the significance of heat exchanger in different field there is a pressure to enhance heat transfer rate on researcher. Requirement of excessive heat transfer from small area generate the concept of close pack heat exchanger. For different applications compact heat exchanger were employ to transfer heat at a much faster rate than the conventional heat exchanger. To expand the fulfillment of heat exchanger researchers had optimized the different process parameters on which the operation of heat transfer depends. To enhance the turbulence interior the heat exchanger dissimilar category of baffles were used, with the help of baffles turbulence were created inner side the heat exchanger. To improve the heat transfer here in this work perforated irregular helical baffles are used to growing the heat transfer. Here in this effort square, circular and triangular perforated intermittent helical baffles were operating to increase the heat transfer rate. It also determine the effect of changing Reynolds number on heat transfer, to evaluate the effect of altered Reynolds number here it considered four altered Reynolds number that is 6000, 8000, 10000 and 12000. It also calculates the significance of Darcy friction factor for discrete perforated interrupted helical baffles at different Reynolds number. After doing the CFD analysis and mathematical calculation it is establish that the baffles having square perforation shows supreme heat transfer as compared to the other categories of perforation. For calculating the effect of dissimilar perforation shape on heat transfer thermal performance of heat exchanger were also calculated in this work.

*Keyword: heat exchanger, helical baffles, perforation, thermal enhancement, flow rate, thermal performance.*

### 1.INTRODUCTION

Heat exchanger is a mechanism that is typically used to happen the resolve of an equipment to switch heat among two procedure streams. The fluids may be detached by using a solid wall to prevent mixing or they may be in direct contact. They are commonly used in space heating, refrigeration, chemical plants, petrochemical plants, petroleum refineries, natural-gas processing, and sewage treatment. Example of heat exchanger is shown in an internal combustion engine where fluids flows through radiator coils and air flows over the coils, which cool the coolant and heats the coming air. Another instance is the heat sink which is a inert heat exchanger that convey the heat generated by an electronic or a mechanical equipment to a fluid norm, air or a liquid fluid.

#### 1.2 Types of heat exchanger

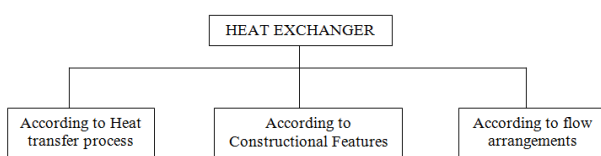

Fig.1.1 Schematic diagram showing the types of heat exchanger

#### 1.2.1 According to Heat transfer process

##### 1.2.1.1 Direct contact type heat exchanger

Here in this exchanger two immiscible fluids are mixed with each other to exchange heat between two fluids. The two streams must also be at the same pressure in a direct contactor, which could result in additional fees. The benefits in utilizing a direct contactor include the dearth of surfaces to corrode or foul, or otherwise degrade the warmth transfer performance. Cooling tower, jet condenser, de-super heaters, open feed water heater are the example of this sort of heat exchanger

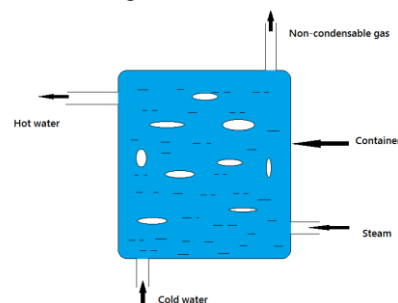

Fig. 1.2 Schematic diagrams showing direct contact heat exchanger

##### 1.2.1.2 Transfer type heat exchanger

In transfer kind or recuperate sort of heat exchanger two fluids flow concomitantly through two tube separated by walls. A recuperator is a distinctive motive counter flow power regaining heat exchanger situated within the supply and deplete air streams of an air coping system, or within the exhaust gases of a industrial process in order to recover the waste heat.

### 1.2.1.3 Regenerator type heat exchanger

In Regenerator type heat exchanger the cold fluid glide and warm fluid flow instead on same surface. In the course of the recent fluid switch the surface wall of warmth exchanger get heated and when the cold fluid flows through it, wall heat get transferred to the cold fluid and heat exchanges in direction that the temperature of cold fluid get increase. The common instance of these kind of heat exchangers is pre-heater for blast furnace, steam power plant and so on.

### 1.3 Types of heat exchanger

Double pipe heat exchangers are the sole exchangers utilized in industries. On one hand, those heat exchangers are low-cost for each style and preservation, creating them an honest want for tiny industries. On the opposite hand, their low performance including the excessive space occupied in massive scales, has semiconductor diode trendy industries to use additional economical heat exchangers like shell and tube or plate. However, owing to the actual fact double pipe heat exchangers are easy, used to device layout basics to students because the elementary tips for all heat exchangers are the equal.

#### 1.3.1 Shell and Tube Heat Exchanger

Shell and tube heat exchangers embrace assortment of tubes. One set of those tubes contains the fluid that has to be compelled to be either heated or cooled. The other fluid runs over the tubes which might be being heated or cooled so as that it's ready to either offer the heat or take in the warmth needed. A set of tubes is understood because the tube package deal and should be made of varied kinds of tubes: easy, lengthwise finned, etc. Shell and tube heat exchangers square measure typically used for excessive-stress programs (with pressures further than thirty bar and temperatures further than 260 °C). That's as a result of the shell and tube heat exchangers square measure sturdy due to their form. Varied thermal layout capabilities have to be compelled to be taken into thought while coming up with the tubes within the shell and tube heat exchangers, there could also be several variations on the shell and tube style. Generally, the ends of every tube square measure joined to plenums via holes in tube sheets. The tubes are often instantly or bent within the form of a U, referred to as U-tubes.

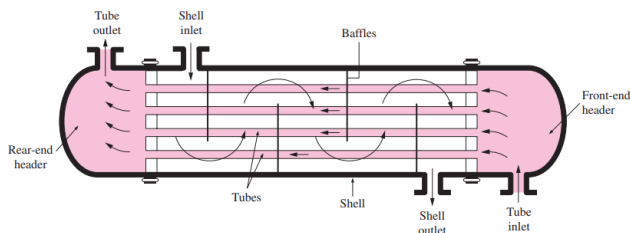

Fig. 1.3 Schematic diagram of a shell and tube heat exchanger

#### 1.3.2 Plate Heat Exchanger

Some other moderately device is that the plate device. Those exchangers square measure composed of the numerous skinny, slightly separated plates that have surface regions and tiny fluid flow passages for heat switch. Advances in seal and brazing technology have created the plate-type device plenty of and plenty of realistic. In HVAC used, giant heat exchangers of this kind square measure cited as plate-and-body, whereas utilized in open loops, these heat exchangers square measure typically of the seal kind to allow periodic activity, cleansing, and review. There square measure many forms of permanently secure plate hotness exchangers, at the side of dip-brazed, vacuum-brazed, and welded plate varieties, and that they square measure typically specific for closed-loop programs like refrigeration. Plate heat exchangers to boot fluctuate inside the kinds of plates that square measure used, and among the configurations of these plates. Some plates might even be sealed with "chevron", dimpled, or different styles, whereby others may additionally have machined fins and/or grooves. Once as compared to shell and tube exchangers, the stacked-plate arrangement typically has decrease quantity and value. Another distinction between the two is that plate exchangers generally serve low to medium pressure fluids, as compared to medium and excessive pressures of shell and tube. A third and crucial distinction is that plate exchangers rent larger countercurrent waft rather than move trendy waft that permits lower approach temperature variations, heat modifications, and accelerated efficiencies.

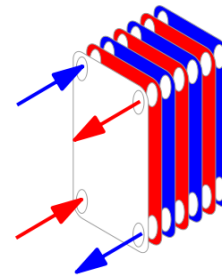

Fig. 1.4 Schematic diagram of a plate heat exchanger

#### 1.4 Selection of heat exchanger

Heat transfer improvement in heat exchangers is sometimes followed with the help of accelerated pressure drop, and for this reason higher pumping power. Therefore, any gain from the improvement in heat switch ought to be weighed con to the fee of the incidental to stress drop. Also, a number of notion got to receive to that fluid ought to skip through the tube aspect and that via the shell aspect. Generally, the goal is to warmth or cool a positive fluid at a acknowledged mass glide fee and temperature to a desired temperature. For that reason, the fee of heat transfer among the potential device is

$$\dot{Q} = \dot{m}C_p(T_{in} - T_{out})$$

Going through catalogs of warmth money handler producers are crushed by suggests that of the type and range of with ease to be had off-the-peg heat exchangers. The correct choice depends upon on varied parts.

### 1.5 Fouling

The improved resistance to each heat transfer and fluid flow because of deposits on a heat transfer surface. Fouling works as associate degree insulating layer on the warmth transfer surface, reducing heat transfer potency or lowering offered flowing surface. The elevated resistance to heat transfer is delineated with the help of an amount observed because the fouling thermal resistance, that is introduced to the complete thermal resistance. The values of fouling thermal resistance have unremarkably been determined to growth with time. To account for the result of fouling on stress drop needs associate degree estimate of the fouling layer thickness.

The rate of warmth money dealer fouling is determined by mistreatment the speed of particle deposition less re-entrainment/suppression. Petroleum money dealer fouling: In business petroleum refinement, petroleum is heated from 21°C (70 °F) to 343 °C (649 °F) previous to getting into the distillation column. A sequence of shell and tube heat exchangers unremarkably trade heat between petroleum and totally different oil streams to warmth the crude to 260°C (500°F) previous to heating during a chamber. Fouling happens on the crude facet of those exchangers because of asphalt quality. The character of asphalt solubility in petroleum become properly shapely. The precipitation of insoluble asphalt in crude heat up trains has been effectively shapely as a primary order response. Cooling water fouling. Cooling water structures are susceptible to fouling. Cooling water unremarkably has high total dissolved solids content material and suspended mixture solids. Localized precipitation of dissolved solids happens at the heat exchange floor because of wall temperatures more than bulk fluid temperature. Low fluid velocities (much but three feet/s) allow suspended solids to decide on the warmth trade surface. Cooling water is often at the tube facet of a shell and tube money dealer as it's clean to simple. To stop fouling, designers typically certify that cooling water pace is larger than zero. 9 m/s and bulk fluid temperature is maintained but 60°C (140 °F). Totally different strategies to govern fouling manage mix the "blind" utility of biocides and anti-scale chemical substances with periodic work testing. The fouling issue is close to zero for a fresh money handler device and can increase with time as a result of the sturdy deposits increase on the warmth exchanger surface. The fouling side depends on the operating temperature and also the speed of the fluids, additionally to the amount of carrier. Fouling can increase with increasing temperature and reducing speed.

## 2. LITERATURE REVIEW

### 2.1 Introduction

In later on the far side year, the changes in computing energy have extended the interest of engineers and researchers to simulate their troubles with procedure and numerical techniques. Plenty of procedure apparatuses and techniques are created within the foremost recent a protracted time to interrupt down liquid float, combustion, and specific techniques of heat alternate. Usage of warmth exchangers in widespread type of uses attracts within the professionals and researchers to paintings on this discipline.

**Camilleri et. al [1]** This paper presents a computationally economical flow network model to predict the flow distribution in compact multi-channel parallel flow heat exchangers. Compact U-type and Z-type heat exchangers with nine parallel channels were used as legal action thereon the model was valid to at intervals 4-8% in terms of non-dimensional flow distribution magnitude relation, the globe magnitude relation AR could be a crucial overall performance parameter which will indicate the degree of flow mal-distribution. Whereas flow mal-distribution was found to be heavily influenced by the friction issue and therefore the style of the manifolds. The impact of the recess jet rate is diminished by commutation the recess pipe by a diffuser that step by step slows the recess flow before getting into the manifold and reduces unexpected entry losses. As an alternative a spreading material is applied at the manifold recess to dissipate the mechanical energy of the flow at the expense of a rise in device pressure.

**Hajabdollahi et.al [2]** A plate fin device was optimally designed by choosing effectiveness and total annual price as two synchronal fitness functions mistreatment particle swarm optimization algorithmic program. owing to the variation of temperature and pressure within the money handler passages, the non-uniform properties are occurred throughout the warmth money handler to generalize the optimization results, the on top of procedure was performed for varied hot aspect recess temperatures. The case of SEG compared with UN-SEG. Moreover, % of variation in TAC inflated by increase of effectiveness and a device with higher hot aspect recess temperature had higher variation in TAC within the case of SEG compared with UNSEG. What is more, % of variation in effectiveness was more or less constant by variation of TAC and its price was higher for the upper hot aspect recess temperature. Finally, device required the lower fin pitch and fin height whereas the upper cold and hot stream lengths within the case of SEG compared with UN-SEG for the mounted price of effectiveness.

**Brandner et.al [3]** The facility transferred per unit volume is especially a operate of the gap between heat supply and warmth sink the smaller this distance, the higher the warmth transfer. Another parameter governing for the warmth transfer is that the lateral characteristic dimension of the warmth transfer structure; within the case of micro

channels, this is often the hydraulic diameter. Decreasing this characteristic dimension into the vary of many 10s of micrometers results in terribly high values for the warmth transfer rate, the warmth transfer in microstructure heat exchangers is increased by decreasing the hydraulic diameter of micro channels, if the look relies on stacked foils comprising micro channels. Or else, it is increased by dynamic the look from micro channels to additional advanced geometries. As associate example, two completely different layouts of small column arrays were compared with reference to their heat transfer capabilities at a given mass flow. A primary example of the economic production application of associate electrically battery-powered small device was conferred. within the future, additional improvement of small heat exchangers are going to be continued by systematic studies of the dependence of warmth transfer properties on geometric structure dimensions and surface properties, to call simply the foremost vital parameters..

Kim et.al [4] The thermal performance and uniformity of frost growth between the front- and rear-sides of tiny channel heat cash dealers was investigated as a perform of the depth of the heat money changer, the pitch of the fins, and so the pitch of the channels. Throughout the defrosting cycle, compared with natural convection, forced convection defrosting resulted among the unit long less water between the fins, leading to improved thermal performance. Device resulted in further uniform frost growth between the front- and rear-sides, And an enlarged heat transfer rate per unit volume. Heat exchangers with a bigger fin pitch showed less reduction within the heat transfer rate throughout the center stages of the experiment owing to additional uniform frost growth with slower frost growth at the front-side. Heat exchangers with an enlarged channel pitch had a bigger initial heat transfer rate thanks to the larger fin surface area; but, the frost growth was less uniform and, as a result, the warmth transfer rate bated considerably within the latter stages of the experiment. Additional uniform frost growth between the front- and rear-sides of the warmth money dealers resulted within the improved thermal performance of the warmth exchanger.

**Iribe et.al [5]** In this work, the moment and heat transfers of a non-Newtonian fluid flowing in steady bedded regime through a plate device at constant wall temperature is studied practice CFD. Single-pass U-type plate heat exchangers with multiple flat plates with and whereas not baffles are used. The impact of plates' variety and distance between plates on the warmth transfer and therefore the pressure drop are investigated. Numbers and distances between plates, and at constant wall temperature was given. For all Reynolds numbers investigated in device with two plates, CFD knowledge were properly fitted to associate degree empirical correlation of the friction issue as a

operate of the generalized Reynolds variety and therefore the quantitative relation between the friction characteristic length and therefore the flow mechanical phenomenon length, that could be a results of associate degree adequate definition of the characteristic lengths.

Pandiyarajan et.al [6] Carried out Associate in Nursing preliminary examination on heat healing from diesel engine fumes utilizing finned shell and tube device and heat reposition framework, a shell Associate in finned tube device incorporated with an IC motor setup to free heat from the fumes gas and a heat vitality reposition tank accustomed store the abundance vitality. A consolidated smart and dormant heat reposition framework consists, factory-made and tried for heat vitality reposition utilizing tube formed stage modification material (PCM) containers. The execution of the motor with and while not device is assessed. It's discovered that regarding 10–15% of fuel management is place away as heat within the consolidated reposition framework that is accessible at reasonably higher temperature for cheap application. The execution parameters with reference to the warmth money dealer and also the capability tank, as an example, live of warmth recuperated, heat lost, charging rate, charging productivity and rate vitality spared square measure assessed.

Naphon et.al [7] Carried out numerical study and trial examine on a flat spiral-coil tube to foresee the stream trademark. The quality  $k-\epsilon$  two-condition turbulence demonstrates was used to breed the turbulent stream and warmth exchange qualities of the liquid. The warmth rate or heat exchange constant had influenced by the divergent constrain. In any case, the load drops likewise increments. He found that the nusselt range and weight drop gotten from the spiral-coil tube area unit terribly nearly one and 0.5 circumstances above that of the straight tube due to the radial constrain.

**Kharat et.al [8]** Investigated that the warmth rate of exchange on a coaxial coiling coil device and build up the association for warmth exchange constant. Heat exchange constant has increased for the tube containing vent gas of the warmth money handler by utilizing CFD reenactment and also the exploratory investigation. The impact of varied operating factors was contemplated. The factors that they had thought-about square measure hole between the coaxial coils, distance across of tube and coil dimension. The warmth exchange coefficients square measure influenced by the coil crevice and also the tube distance across. They found that the warmth exchange constant diminishes with the enlargement in coil crevice. With the increment in tube distance across the warmth exchange constant increments.

**Spadaccini et.al [9]** In this work it conduct the fuel cooled thermal management, that is together with energy-absorbing cracking and organic compound fuels reforming, is Associate in Nursing sanctionative technology for traditional aero engines and offers potential for cycle enhancements and waste product emissions management in turbine engine applications. The prosperous

implementation of this technology is, however, predicated on the employment of standard multi-component organic compound fuels Associate in an understanding of the combustion characteristics of the reformed fuel mixture. the target of this analysis is to develop and demonstrate the technologies necessary for utilizing standard multi-component organic compound fuels for fuel-cooled thermal management, together with the event of the energy-absorbing potential of JP-7 Associate in JP-8+100 is like an exhibition for combustion of supercritical/endothermic fuel mixtures, and intangible style of a fuel-air device.

**Jang et.al [10]** Conducted the experimental study mistreatment an infrared thermo vision to observe temperature distribution over a plate-fin surface within the plate finned-tube heat exchangers. The differentiation of the temperature perform comes to work out the native convective heat transfer coefficients on the tested fin, employing a native part lumped physical phenomenon equation enclosed the convective result on the boundaries with experimental information. It's disclosed that the infrared diagnostic technique is capable of quickly detection location and transition extent and separation regions of the physical phenomenon over the whole surface of the tested and analyzed models. An infrared thermo vision has been used to check and quantitatively appraise within the world temperature distribution over the fin surface within a plate finned-tube device. Following the temperature worth known at every element, the native convective heat transfer coefficients over the fin are determined by means that of an impression volume based mostly finite distinction formulation. The results incontestable that the infrared diagnostic technique is quickly capable of detection location and transition extent and separation regions of the physical phenomenon over the whole surface of the take a look at model. Through the comparison of the take a look at results on the strategy region of the in-line and staggered arrangements, it's less difficult to grasp or interpret the elaborate dynamic phenomena of flow existed within the heat exchangers.

**Wang et.al [11]** Investigated concerning the warmth transfer and pressure drop characteristics of typical wavy fin-and-tube heat exchangers were administrated. Within the current study, eighteen wavy samples of fin and tube heat exchangers with in contrast to geometrical parameters, with the amount of tube rows, fin pitch, and flow arrangements, were tested and analyzed in a very structure. Results are bestowed as plots of the Fanning friction issue  $f$  and also the Colburn  $j$  issue against painter variety supported tube collar diameter within the vary of four hundred to 8000. For the staggered layout at an occasional painter variety region, no detectable row result is discovered. However, at higher painter numbers, downstream turbulence causes a better heat transfer constant with an increasing within the variety of tube rows. However, the warmth transfer characteristic of the inline layout differs from that of the staggered layout for two reasons; because the initial one is that the thermal physical phenomenon will increase at low variety regions then breaks up at high Reynolds variety regions; and also the other is smaller bypass flowing. The wavy fin heat transfer characteristics for each inline and staggered layouts are

comparatively freelance of fin pitch. It's found that the friction factors are freelance of the amount of tube rows for each inline and staggered layout.

**Muchengwu et.al [12]** It investigates the Fluid flow and warmth transfer over a multi-row (1-6 rows) plate-fin and tube device are studied numerically and by experimentation. Fluid flow is incompressible, 3 dimensional and laminar. The consequences of various geometrical parameters like tube arrangement, tube row ranges and fin pitch are investigated well for the Reynolds number starting from sixty to 900. the typical heat transfer constant of staggered arrangement is 15%-27% on top of that of in-lined arrangement, whereas the pressure drop of staggered configuration is 20%-25% on top of that of in-lined configuration. For in-lined array, the most price of Nusselt range for the first row round the tube surface is bigger than that for the staggered array; there are two native maximums for rows 2-4, For a staggered array, second model for a clean tube bundle overestimates the typical Nusselt range, while, for Associate in Nursing in-lined array, the alternative trend is true. It's additionally found that the amount of tube row incorporates a little impact on the typical heat transfer constant because the row numbers are bigger than four.

**Anurjew et.al [13]** Investigated completely different small structure cross flow heat exchangers and considered their heat exhibitions. The facility transfer per unit volume is directly proportional to the perform of warmth supply and warmth sink for higher heat transfer lesser are going to be the space. They found that heat transfer are often upgraded by decreasing the pressure driven distance across of the small channels and in their work conjointly emphasize the electrically.

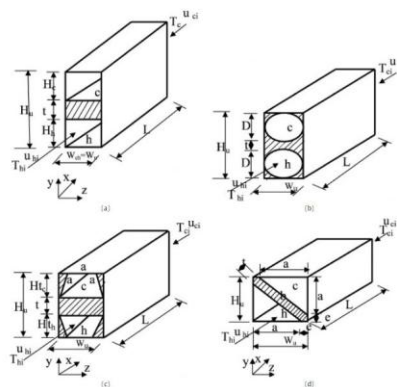

Fig. 2.1 Schematic of a heat exchanger unit [13]

**Tanget. al [14]** In the gift paper they did investigation through by experimentation on fin-and-tube heat exchangers with the Sir Joshua Reynolds range varies from 4000 to ten thousand, and the improvement of warmth money handler with vortex generator (VGs) is additionally self-addressed and at high Sir Joshua Reynolds numbers, best heat transfer performance achieved by slit fin device. The high angle of attack, low height and {better} length of vortex generators can cause better overall performance of warmth exchangers with VGs. The optimized vortex-generator fin will give higher heat transfer performance than slit fin. **Yang et al. [15]** It is vital to get the warmth transfer characteristics of hard-hitting syngas within the cooler. Heat transfer in convection cooling section of

controlled coal gasified with the membrane whorled coils and membrane snaky tubes below air mass is through an experiment investigated. Air mass single gas (He or N<sub>2</sub>) and their mixture (He + N<sub>2</sub>) gas function the check media within the check pressure vary from zero.5 MPa to 3.0 MPa. The results show that the convection heat transfer constant of air mass gas is influenced by the operating pressure, gas composition and symmetry of flow round the coil, of that the operating pressure is that the most important issue. The typical convection heat transfer coefficients for varied gases in heat exchangers area unit consistently analyzed, and therefore the correlations between alphabetic character and Re for two styles of membrane heat exchangers area unit obtained.

Yakar et. al [16] Examined by experimentation the air aspect heat exchange constant and also the heat steady electrical phenomenon in finned tubes. Water is employed because the heating medium, in turbulent conditions and streaming at varied temperatures within the tube. Petukhov's relationship has been chosen to determine the water heat move constant within the tube. A fitting of the knowledge provides a relationship to the three containers of assorted outside breadth (30 millimeter, 22 mm, and 15.6 mm) that concurs exceptionally well with the experimental esteems. Assessed the contact heat resistance amongst balances and tubes to increment visible of the Reynolds range and also the heat contact resistance square measure evaluated and adjusted.

Jayakumar et al. [17] The heat exchanger is analyzed considering conjugate heat transfer and temperature dependent properties of warmth transport media. The CFD predictions match fairly well with the experimental results inside experimental error limits. Supported the results a correlation was developed to calculate the inner heat transfer constant of the turbinate coil. Supported the boldness gained within the CFD predictions, the results generated beneath totally different conditions could use additional to get a generalized correlation. additionally for prediction of warmth transfer during a state of affairs of fluid-to- fluid heat transfer, because it happens within the case during a device, discretional boundary conditions like constant wall temperature, constant heat flux.

Venugopal et al [18] Conducted associate experimental study k regarding on the amalgamated convective heat move in an exceedingly vertical channel loaded with tinny porous structures. The semi permeable medium model created within the gift examination shows thermo-hydrodynamic execution like those found in metal froths. A correlation has been made for foreseeing the Nusselt variety from the pure mathematics beneath thought. The key curiosity within the gift work is that the development of another relationship for the Nusselt variety that doesn't need any knowledge from hydraulics investigations. Over the scope of parameters thought of, the most important increment within the traditional Nusselt variety of 4.52 times that for clear stream is seen with a semipermeable material of consistency of 0.85.

Lingdong et.al [19] Conducted Numerical studies to research the airside thermal-hydraulic characteristics of blank tube bank and plain finned tube heat exchangers meant to be used in aero-engine cooling. The exchangers

use little diameter tubes (3.0 mm) with compact tube layout and operate at high temperatures with massive temperature changes over the money handler depth. Calculations are performed for frontal air velocities between five and twenty m/s, airside heat transfer and pressure loss characteristics of blank tube bank and plain finned tube heat exchangers are numerically foretold considerably of the air property variations caused by the air temperature variations.

Pawar et.al [20] Investigated the experimental analysis on constant temperature steady state and non-isothermal unsteady state conditions in spiraling coils. that they had thought of each the Newtonian moreover as non-Newtonian fluids for operating fluid. For Newtonian fluid they thought of water and glycerol-water mixture (10 and 2 hundredth glycerol). For non-Newtonian fluid they thought of zero.5–1% (w/w) dilute liquid compound solutions of Na Carboxy methyl cellulose and Na Alginate. The correlation was distinguished between the Nusselt range and non-dimensional range, 'M', Prandtl range and coil curvature quantitative relation. They found the warmth transfer rate beneath equal steady state and non-isothermal unsteady state conditions in laminar and flow conditions.

### 3. CONCLUSION AND FUTURE WORK

#### 3.1 Conclusion

From the above analysis following conclusion were drawn

1. From the numerical investigation of discontinuous helical perforated baffles, it is determine that the heat transfer rises with increase in Re number.
2. The value of Nu number rises with rise in Re number of cold fluid flowing in the outer pipe.
3. The value of Nu number is greater for heat exchanger having discontinuous helical baffles with square perforation as compared to the heat exchanger with circular and triangular perforation.
4. Darcy friction factor is reducing with increase in Re Number. Whereas the value of Friction factor is supreme for square perforation as compared to the other perforation shapes.
5. Thermal performance was calculated to measure the overall thermal enhancement in heat exchanger having different shapes of perforations.
6. Through calculation it is found that the value of thermal performance of heat exchanger having discontinuous helical baffles with square perforation is maximum as compared to the circular and triangular perforations.
7. Form the numerical analysis it is determine that the heat transfer is supreme in case of heat exchanger having discontinuous helical baffles with square perforation

#### 3.1 Future Scope

1. Researcher can work on the helix angle to increase the performance of heat exchanger.
2. People can work on the continuous turbulator and different shapes of perforation.
3. Researchers can work on the thickness of baffles placed inside the heat exchanger for enhance the turbulence.

## REFERENCES

1. Camilleri R, Howey D.A, McCulloch M.D., "Predicting the flow distribution in compact parallel flow heat exchangers". *Applied Thermal Engineering* 2015; 90: 551-558.
2. Hassan H, Zahra H., "Investigating the effect of properties variation in optimum design of compact heat exchanger using segmented method". *Chemical Engineering Research and Design* 2016; 112: 46-55.
3. J.J. Brandner, E. Anurjew, L. Buhn, E. Hansjosten, T. Henning, U. Schygulla, A. Wenka, K. Schubert, "Concept and realization of microstructure heat exchangers for enhanced heat transfer", *Experimental Thermal and Fluid Science* 30 (2006) 801–809.
4. Kyoungmin Kim, Min-Hwan Kim, Dong Rip Kim, Kwan-Soo Lee, "Thermal performance of microchannel heat exchangers according to the design parameters under the frosting conditions", *International Journal of Heat and Mass Transfer* 71 (2014) 626–632
5. Erika Y. Rios-Irube , Maritza E. Cervantes-Gaxiola, Eusiel Rubio-Castro, Oscar M. Hernández-Calderón, "Heat transfer analysis of a non-Newtonian fluid flowing through a Plate Heat Exchanger using CF" *Applied Thermal Engineering* 101 (2016) 262–272
6. V. Pandiyarajana, M. Chinna Pandianb, E. Malana, R. Velraja\*, R.V. Seeniraja "Experimental investigation on heat recovery from diesel engine exhaust using finned shell and tube heat exchanger and thermal storage system" *Applied Energy*, Elsevier 88 (2011) 77-87.
7. Paisarn Naphon, "Study on the heat transfer and flow characteristics in a spiral-coil tube" *International Communications in Heat and Mass Transfer*, Elsevier 38 (2011) 69-74.
8. Rahul Kharat, Nitin Bhardwaj\*, R.S.Jha, "Development of heat transfer coefficient correlation for concentric helical coil heat exchanger" *International Journal of Thermal Sciences*, Elsevier 48 (2009) 2300–2308.
9. He Huang, Louis J. Spadaccini and David R. Sobel., "Fuel-Cooled Thermal Management For Advanced Aero Engines", *Proceedings of ASME TURBO EXPO 2002*, GT-2002-30070 .
10. Herchang Ay., JiinYuh Jang., Jer-Nan Yeh., "Local heat transfer measurements of plate finned-tube heat exchangers by infrared thermography", *International Journal of Heat and Mass Transfer* 45 (2002) 4069–4078.
11. C. C. Wang, W. L. Fu, C. T. Chang, "Heat Transfer and Friction Characteristics of Typical Wavy Fin-and-Tube Heat Exchangers", Elsevier, *Experimental Thermal and Fluid Science*, 14 (1997) 174-186.
12. Jiin-Yuh Jang, Mu-Cheng Wu, Wen - Jeng Chang, "Numerical and experimental studies of three dimensional plate-fin and tube heat exchangers", Pergamon, *International Journal of Heat and Mass Transfer*, Vol. -39 (1996) 3057- 3066.
13. J.J. Brandner, E. Anurjew, L. Buhn, E. Hansjosten, T. Henning, U. Schygulla, A. Wenka, K. Schubert, "Concept and realization of microstructure heat exchangers for enhanced heat transfer", *Experimental Thermal and Fluid Science* 30 (2006) 801–809.
14. L.H. Tang, M. Zeng, Q.W. Wang, "Experimental and numerical investigation on air-side performance of fin-and-tube heat exchangers with various fin patterns" *Experimental Thermal and Fluid Science* 33 (2009) 818–827
15. Zhen Yang., Zhao Zhenxing., Liu Yinhe., Chang Yongqiang., Cao Zidong., "Convective heat transfer characteristics of high-pressure gas in heat exchanger with membrane helical coils and membrane serpentine tubes", *Experimental Thermal and Fluid Science*, vol.-35 (2011) 1427–1434.
16. Yakar, G & Karabacak, R, " Investigation of thermal performance of perforated finned heat exchangers", *Experimental Heat Transfer* vol.28, (2015): pp.354-365.
17. Jayakumar J.S., Mahajani S.M., Mandal J.C., Vijayan P.K., BhoiRohidas., "Experimental and CFD estimation of heat transfer in helically coiled heat exchangers", *International journal of Chemical Engineering Research and Design*, Vol.-86 (2008):221-232.
18. G. Venugopal, C. Balaji, S.P. Venkateshan, "Experimental study of mixed convection heat transfer in a vertical duct filled with metallic porous structures", *International Journal of Thermal Sciences* 49 (2010) 340–348.
19. Lingdong Gua, Jingchun Mina\*, Xiaomin Wub, Lijun Yangc; "Airsides heat transfer and pressure loss characteristics of bare and finned tube heat exchangers used for aero engine cooling considering variable air properties" ; *International Journal of Heat and Mass Transfer*, Elsevier 108 (2017) 1839 - 1849.
20. S.S. Pawar\*, Vivek K. Sunnapwar, "Experimental and CFD investigation of convective heat transfer in helically coiled tube heat exchanger" ; *Chemical Engineering Research and Design* 1475 (2014) Article in press.